

# PA SERIES

# W8-740C

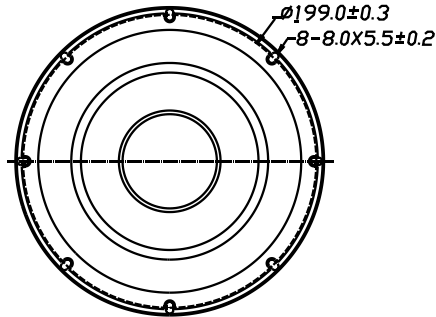
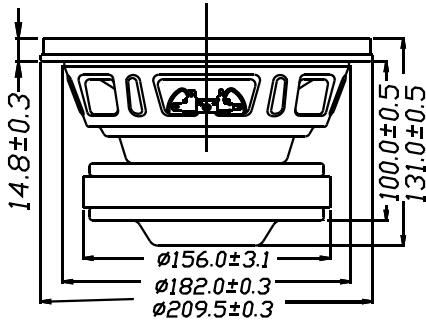

- LONG THROW HIGH POWER LOADING DESIGN ( $X_{max}=12\text{mm}$ )
- PAPER CONE WITH FOAM SURROUND (LIGHT WEIGHT & HIGH STIFFNESS)
- VENTED POLE PIECE
- STAMPED STEEL BASKET
- SUITABLE FOR SUBWOOFER APPLICATION
- MAGNETIC VOICE COIL

## 8" PAPER SUBWOOFER

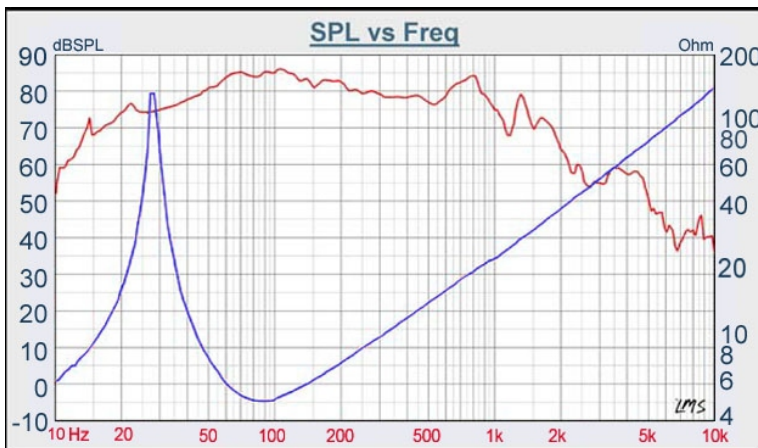

DIAPHRAGM MTL	Paper
SURROUND MTL	Foam
NOMINAL IMPEDANCE	4
DCR IMPEDANCE	3.2
SENSITIVITY 1W/1m	84 dB
FREQUENCY RESPONSE	28-1K Hz
FREE AIR RESONANCE	28 Hz
VOICE COIL DIAMETER	50 mm
AIR GAP HEIGHT	8 mm
RATED POWER INPUT	120 W
MAXIMUM POWER INPUT	230 W
FORCE FACTOR, BL	13.35TM
MAGNET WEIGHT (50 oz)	1427 g
MOVING MASS	95 g
FERROFLUID ENHANCED	No
SUSPENSION COMPLIANCE	333 MN <sup>-1</sup>
EFFECTIVE PISTON AREA	0.022 M <sup>2</sup>
Levc	3.1811 mH
Zo	113.9893 ohm
X-max	12 mm
Vas	23 Litr
Qts	0.30
Qms	10.53
Qes	0.30



P.O. BOX 10-53 NEI HU, TAIPEI, TAIWAN  
VOICE 886.2.26570282 FAX 886.2.26580166